

CBT3253A

Dual 1-of-4 FET multiplexer/demultiplexer

Rev. 6 — 25 February 2021

Product data sheet

1. General description

The CBT3253A is a dual single-pole,4-throw bus switch. The device features two output enable inputs ($n\overline{OE}$) and two select inputs (S0 and S1). When $n\overline{OE}$ are LOW the switch is enabled and the select inputs can be used to connect the nA terminal to one of the four associated nB terminals.

2. Features and benefits

- 5 Ω switch connection between two ports
- Direct interface with TTL levels
- Overvoltage tolerant control inputs to 5.5 V
- Minimal propagation delay through the switch
- Latch-up protection exceeds 100 mA per JEDEC standard JESD78 class II level A
- ESD protection:
 - HBM JESD22-A114E exceeds 2000 V
 - MM JESD22-A115-A exceeds 200 V
 - CDM JESD22-C101C exceeds 1000 V
- Multiple package options
- Specified from -40 °C to +85 °C

3. Ordering information

Table 1. Ordering information

Type number	Temperature range	Package		
		Name	Description	Version
CBT3253AD	-40 °C to +85 °C	SO16	plastic small outline package; 16 leads; body width 3.9 mm	SOT109-1
CBT3253ADS	-40 °C to +85 °C	SSOP16 [1]	plastic shrink small outline package; 16 leads; body width 3.9 mm; lead pitch 0.635 mm	SOT519-1
CBT3253APW	-40 °C to +85 °C	TSSOP16	plastic thin shrink small outline package; 16 leads; body width 4.4 mm	SOT403-1

[1] Also known as QSOP16.

4. Functional diagram

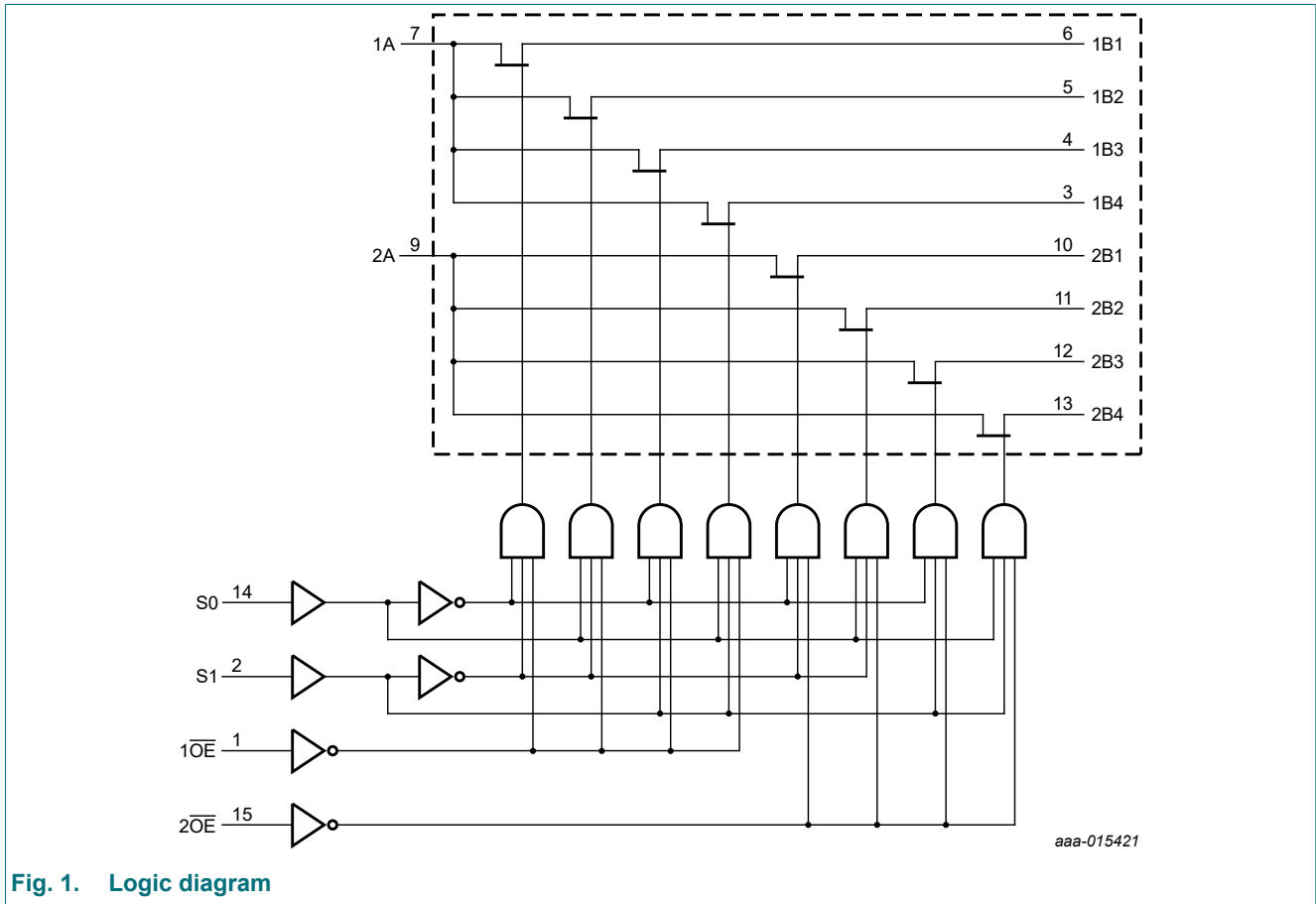

Fig. 1. Logic diagram

5. Pinning information

5.1. Pinning

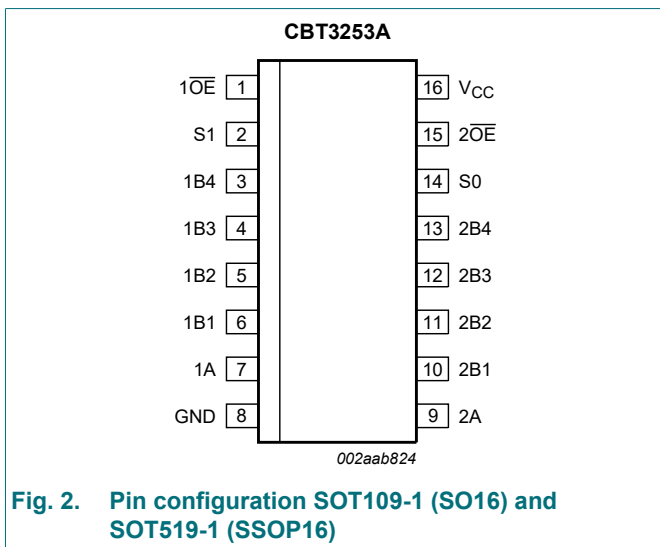

Fig. 2. Pin configuration SOT109-1 (SO16) and SOT519-1 (SSOP16)

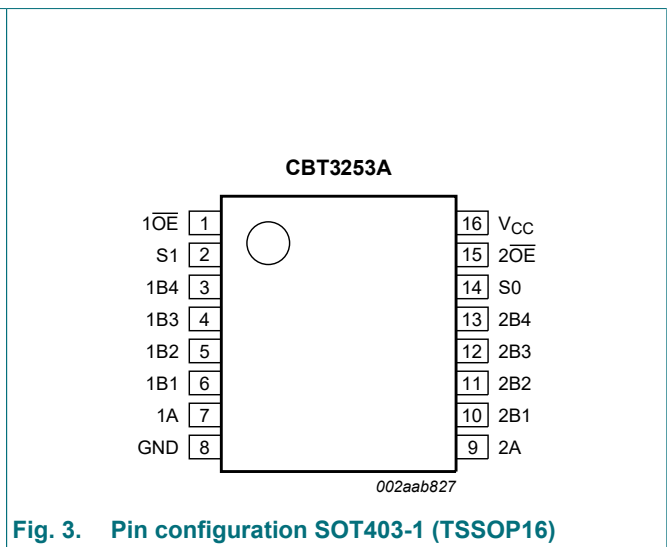

Fig. 3. Pin configuration SOT403-1 (TSSOP16)

5.2. Pin description

Table 2. Pin description

Symbol	Pin	Description
1OE, 2OE	1, 15	output enable (active LOW)
S1, S0	2, 14	select control input
1B4, 1B3, 1B2, 1B1	3, 4, 5, 6	1B outputs/inputs
1A	7	1A input/output
GND	8	ground (0 V)
2A	9	2A input/output
2B1, 2B2, 2B3, 2B4	10, 11, 12, 13	2B outputs/inputs
V _{CC}	16	positive supply voltage

6. Functional description

Table 3. Function selection

H = HIGH voltage level; L = LOW voltage level; X = Don't care.

Inputs				Switch
1OE	2OE	S1	S0	
X	H	X	X	disconnect 2A to 2Bn
H	X	X	X	disconnect 1A to 1Bn
L	L	L	L	1A to 1B1 and 2A to 2B1
L	L	L	H	1A to 1B2 and 2A to 2B2
L	L	H	L	1A to 1B3 and 2A to 2B3
L	L	H	H	1A to 1B4 and 2A to 2B4

7. Limiting values

Table 4. Limiting values

In accordance with the Absolute Maximum Rating System (IEC 60134). Voltages are referenced to GND (ground = 0 V).

Symbol	Parameter	Conditions	Min	Max	Unit
V _{CC}	supply voltage		-0.5	+7.0	V
V _I	input voltage	[1]	-0.5	+7.0	V
I _{SW}	switch current	continuous current through each switch	-	128	mA
I _{IK}	input clamping current	V _I < 0 V	-50	-	mA
T _{stg}	storage temperature		-65	+150	°C
P _{tot}	total power dissipation	T _{amb} = -40 °C to +85 °C	-	500	mW

[1] The input and output negative voltage ratings may be exceeded if the input and output clamp current ratings are observed.

8. Recommended operating conditions

Table 5. Operating conditions

All unused control inputs of the device must be held at V_{CC} or GND to ensure proper device operation.

Symbol	Parameter	Conditions	Min	Max	Unit
V_{CC}	supply voltage		4.5	5.5	V
V_{IH}	HIGH-level input voltage		2.0	-	V
V_{IL}	LOW-level input voltage		-	0.8	V
T_{amb}	ambient temperature	operating in free-air	-40	+85	°C

9. Static characteristics

Table 6. Static characteristics

At recommended operating conditions. Voltages are referenced to GND (ground = 0 V). $T_{amb} = -40\text{ °C}$ to $+85\text{ °C}$.

Symbol	Parameter	Conditions	Min	Typ [1]	Max	Unit
V_{IK}	input clamping voltage	$V_{CC} = 4.5\text{ V}$; $I_I = -18\text{ mA}$	-	-	-1.2	V
V_{pass}	pass voltage	$V_I = V_{CC} = 5.0\text{ V}$; $I_O = -100\text{ }\mu\text{A}$	3.6	3.9	4.2	V
I_I	input leakage current	$V_{CC} = 5.5\text{ V}$; $V_I = \text{GND}$ or 5.5 V	-	-	± 1	μA
I_{CC}	supply current	$V_{CC} = 5.5\text{ V}$; $I_O = 0\text{ mA}$; $V_I = V_{CC}$ or GND	-	-	3	μA
ΔI_{CC}	additional supply current	per input; $V_{CC} = 5.5\text{ V}$; one input at 3.4 V , other inputs at V_{CC} or GND [2]	-	-	2.5	mA
C_I	input capacitance	control pins; $V_I = 3\text{ V}$ or 0 V	-	4.5	-	pF
$C_{io(off)}$	off-state input/output capacitance	A port; $V_O = 3\text{ V}$ or 0 V ; $n\overline{OE} = V_{CC}$	-	11.4	-	pF
		B port; $V_O = 3\text{ V}$ or 0 V ; $n\overline{OE} = V_{CC}$	-	3.8	-	pF
$C_{io(on)}$	on-state input/output capacitance	A port and B port	-	18.6	-	pF
R_{ON}	ON resistance	$V_{CC} = 4.5\text{ V}$ [3]				
		$V_I = 0\text{ V}$; $I_I = 64\text{ mA}$	-	5	7	Ω
		$V_I = 0\text{ V}$; $I_I = 30\text{ mA}$	-	5	7	Ω
		$V_I = 2.4\text{ V}$; $I_I = -15\text{ mA}$	-	10	15	Ω

[1] All typical values are measured at $V_{CC} = 5\text{ V}$; $T_{amb} = 25\text{ °C}$.

[2] This is the increase in supply current for each input that is at the specified TTL voltage level rather than V_{CC} or GND.

[3] Measured by the voltage drop between the A and the B terminals at the indicated current through the switch. The lowest voltage of the two (A or B) terminals determines the ON resistance.

10. Dynamic characteristics

Table 7. Dynamic characteristics

$T_{amb} = -40\text{ }^{\circ}\text{C}$ to $+85\text{ }^{\circ}\text{C}$; $V_{CC} = 4.5\text{ V}$ to 5.5 V ; for test circuit, see Fig. 6.

Symbol	Parameter	Conditions	Min	Max	Unit
t_{pd}	propagation delay	Sn to nA; see Fig. 4 [1] [2]	1.2	6.2	ns
		nA to nBn or nBn to nA; see Fig. 4 [1] [2]	-	0.25	ns
t_{en}	enable time	Sn to nBn; see Fig. 5 [3]	1.3	6.3	ns
		n $\overline{\text{OE}}$ to nA or nBn; see Fig. 5 [3]	1.4	6.4	ns
t_{dis}	disable time	Sn to nBn; see Fig. 5 [4]	1.1	7.2	ns
		n $\overline{\text{OE}}$ to nA or nBn; see Fig. 5 [4]	1.0	7	ns

- [1] This parameter is warranted but not production tested. The propagation delay is based on the RC time constant of the typical ON resistance of the switch and a load capacitance, when driven by an ideal voltage source (zero output impedance).
- [2] t_{PLH} and t_{PHL} are the same as t_{pd} .
- [3] t_{PZL} and t_{PZH} are the same as t_{en} .
- [4] t_{PLZ} and t_{PHZ} are the same as t_{dis} .

10.1. Waveforms and test circuit

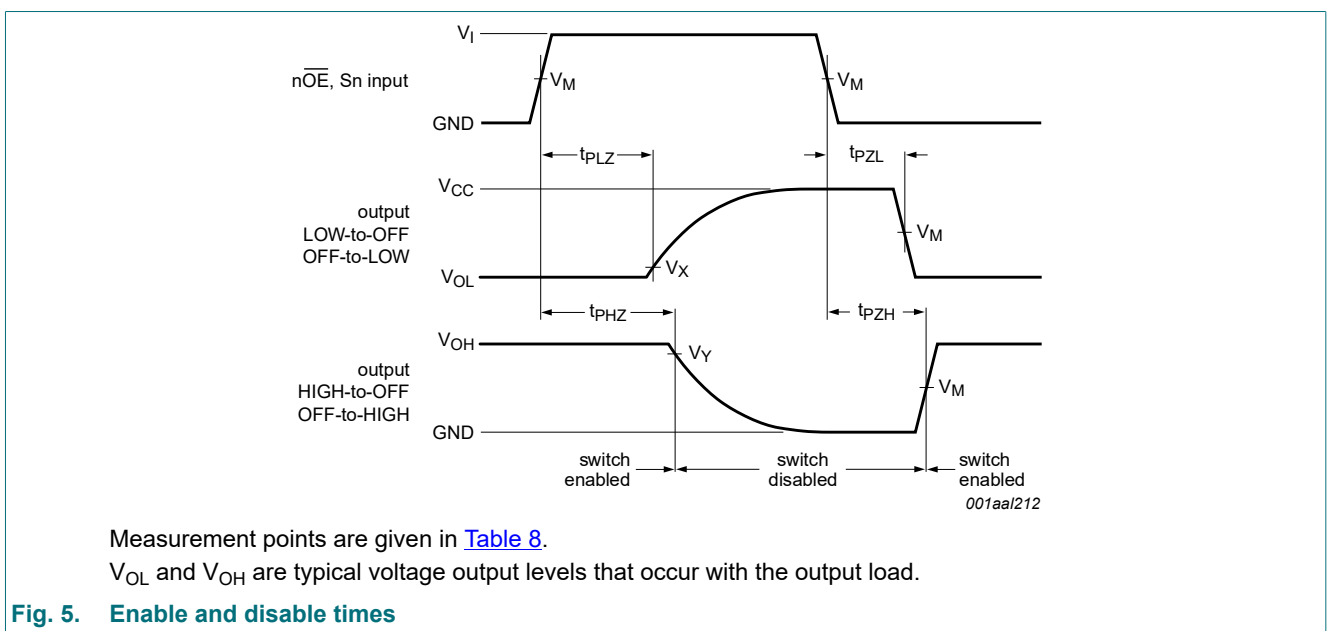
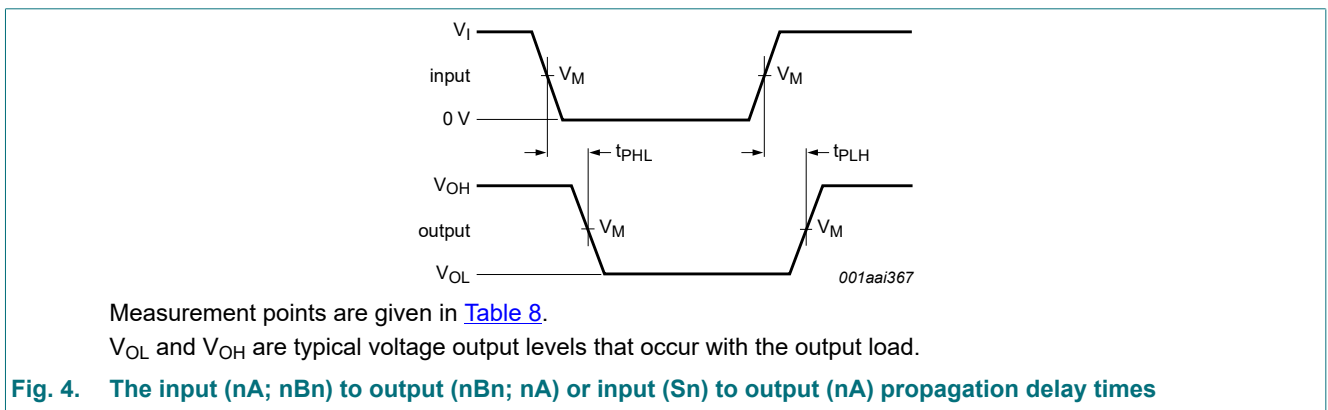
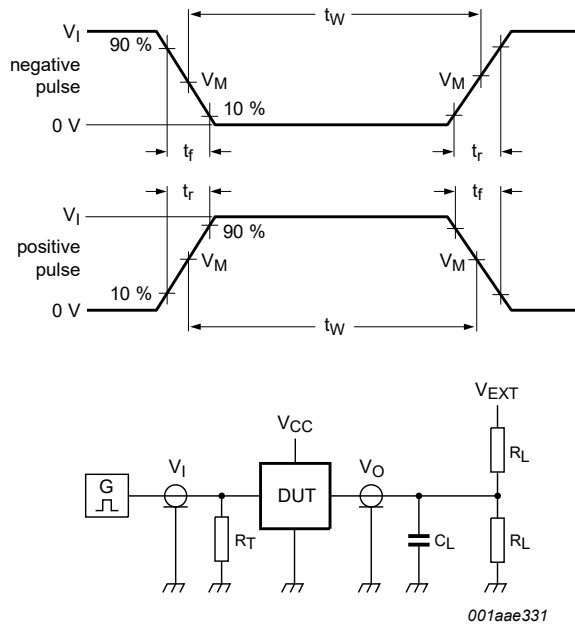

Table 8. Measurement points

Supply voltage	Input		Output		
V_{CC}	V_I	V_M	V_M	V_X	V_Y
4.5 V to 5.5 V	GND to 3.0 V	1.5 V	1.5 V	$V_{OL} + 0.3 V$	$V_{OH} - 0.3 V$



Test data is given in [Table 9](#).

Definitions for test circuit:

R_L = Load resistance.

C_L = Load capacitance including jig and probe capacitance.

R_T = Termination resistance should be equal to the output impedance Z_o of the pulse generator.

V_{EXT} = External voltage for measuring switching times.

Fig. 6. Test circuit for measuring switching times

Table 9. Test data

Supply voltage	Input		Load		V_{EXT}		
V_{CC}	V_I	t_r, t_f	C_L	R_L	t_{PLH}, t_{PHL}	t_{PLZ}, t_{PZL}	t_{PHZ}, t_{PZH}
4.5 V to 5.5 V	GND to 3.0 V	$\leq 2.5 \text{ ns}$	50 pF	500 Ω	open	7.0 V	open

11. Package outline

SO16: plastic small outline package; 16 leads; body width 3.9 mm

SOT109-1

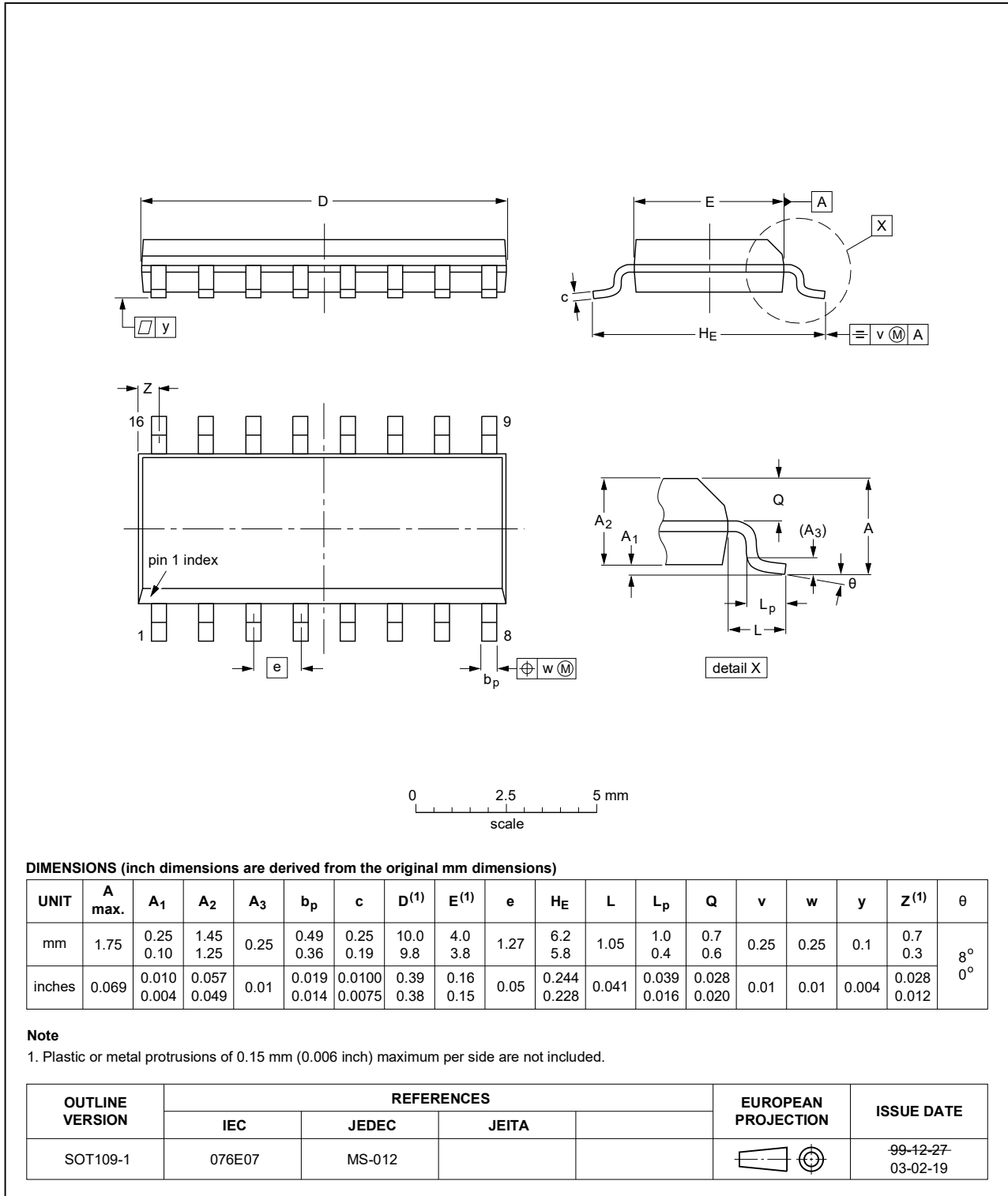

Fig. 7. Package outline SOT109-1 (SO16)

SSOP16: plastic shrink small outline package; 16 leads; body width 3.9 mm; lead pitch 0.635 mm SOT519-1

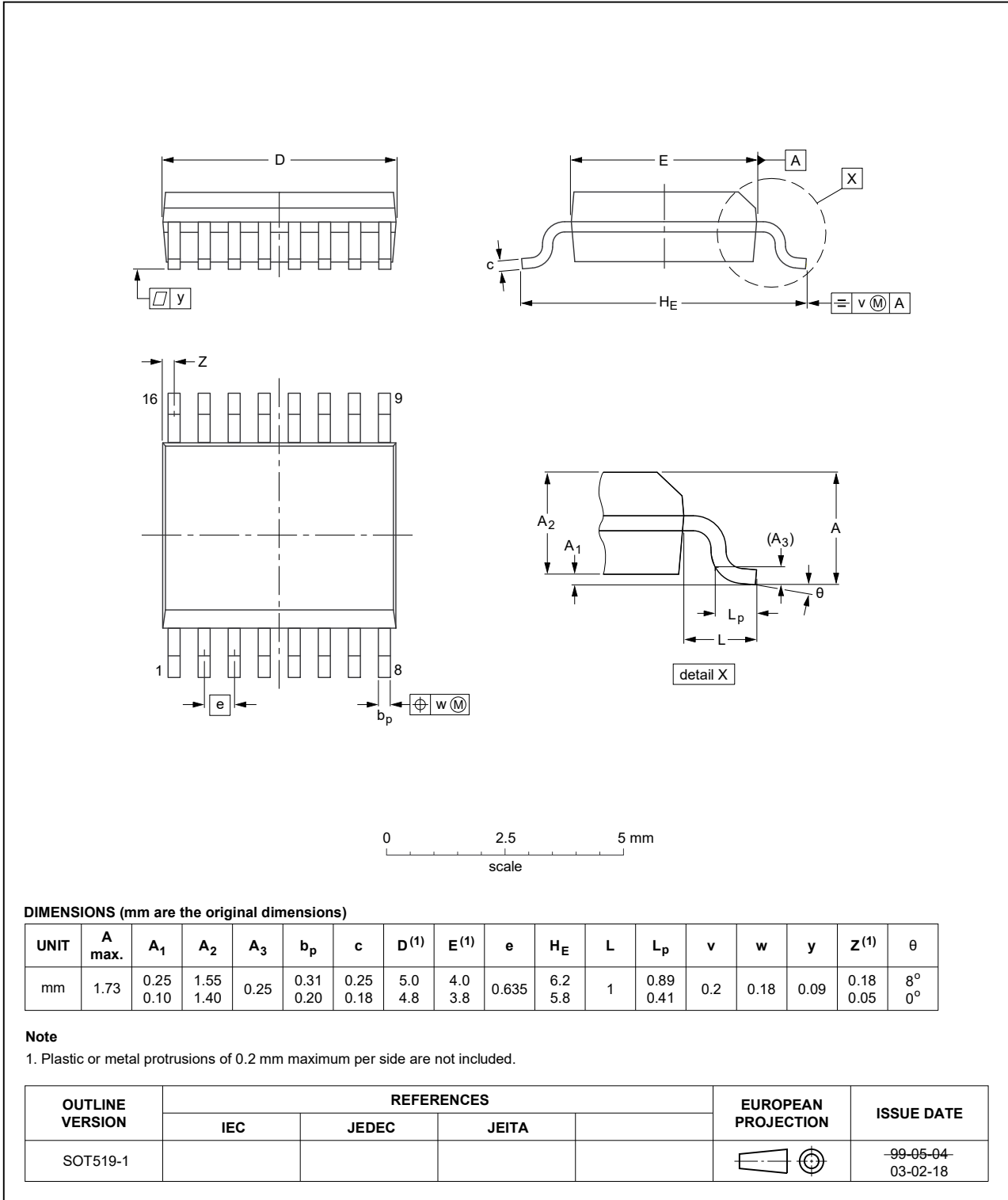

Fig. 8. Package outline SOT519-1 (SSOP16)

TSSOP16: plastic thin shrink small outline package; 16 leads; body width 4.4 mm

SOT403-1

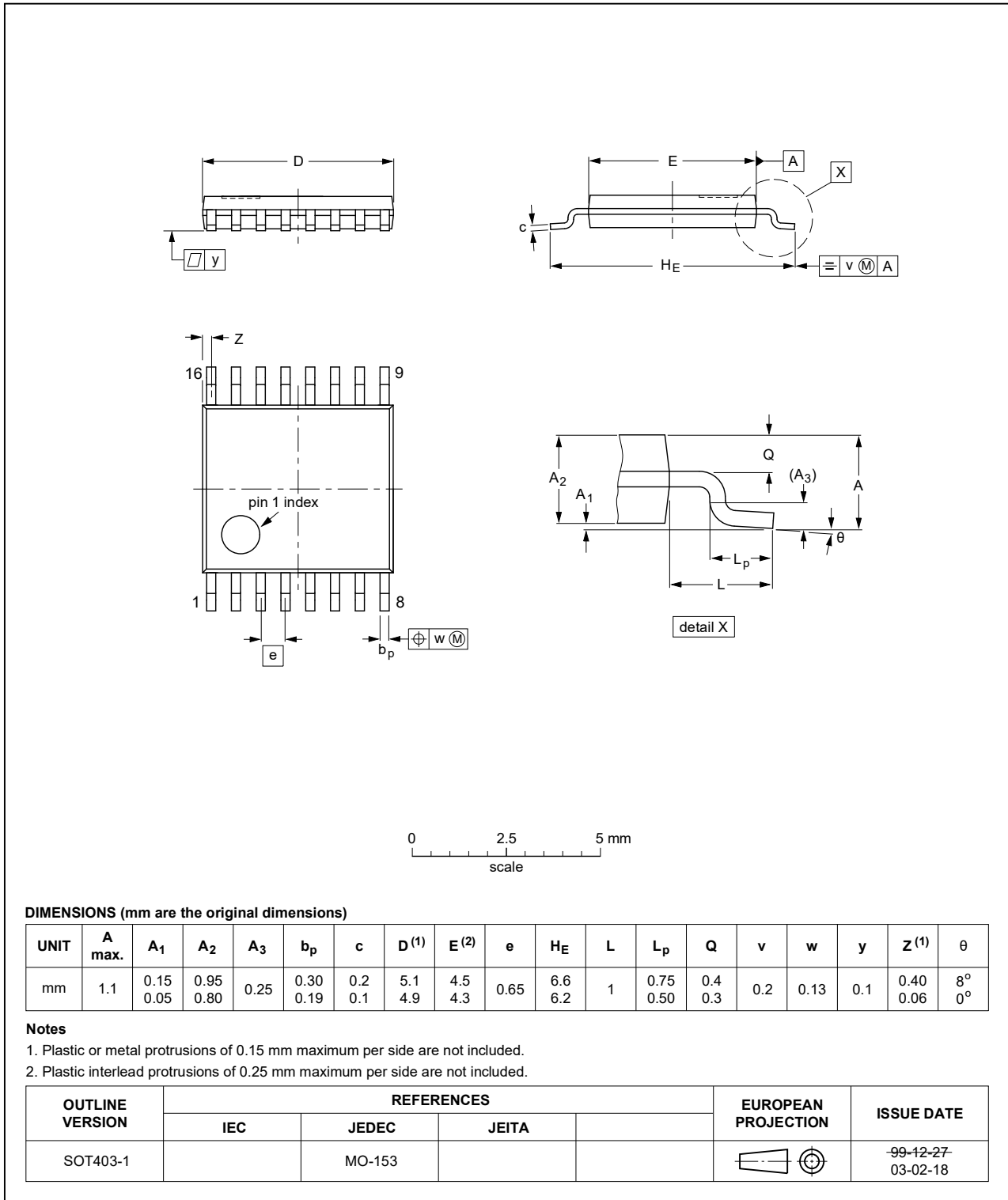

Fig. 9. Package outline SOT403-1 (TSSOP16)

12. Abbreviations

Table 10. Abbreviations

Acronym	Description
CDM	Charged Device Model
DUT	Device Under Test
ESD	ElectroStatic Discharge
HBM	Human Body Model
MM	Machine Model
TTL	Transistor-Transistor Logic

13. Revision history

Table 11. Revision history

Document ID	Release date	Data sheet status	Change notice	Supersedes
CBT3253A v.6	20210225	Product data sheet	-	CBT3253A v.5
Modifications:	<ul style="list-style-type: none"> Type number CBT3253ADB (SOT338-1 / SSOP16) removed. 			
CBT3253A v.5	20170509	Product data sheet	-	CBT3253A v.4
Modifications:	<ul style="list-style-type: none"> The format of this data sheet has been redesigned to comply with the identity guidelines of Nexperia. Legal texts have been adapted to the new company name where appropriate. 			
CBT3253A v.4	20141031	Product data sheet	-	CBT3253A v.3
Modifications:	<ul style="list-style-type: none"> Section 1: text changed to align with the function of the device. Fig. 1: schematic changed. Section 6: switch description changed to align with the function of the device. Section 10: typo corrected, the conditions for enable and disable times are swapped. 			
CBT3253A v.3	20130924	Product data sheet	-	CBT3253A v.2
Modifications:	<ul style="list-style-type: none"> Section 9: values for pass voltage modified. 			
CBT3253A v.2	20070208	Product data sheet	-	CBT3253A v.1
CBT3253A v.1	20051024	Product data sheet	-	-

14. Legal information

Data sheet status

Document status [1][2]	Product status [3]	Definition
Objective [short] data sheet	Development	This document contains data from the objective specification for product development.
Preliminary [short] data sheet	Qualification	This document contains data from the preliminary specification.
Product [short] data sheet	Production	This document contains the product specification.

- [1] Please consult the most recently issued document before initiating or completing a design.
- [2] The term 'short data sheet' is explained in section "Definitions".
- [3] The product status of device(s) described in this document may have changed since this document was published and may differ in case of multiple devices. The latest product status information is available on the internet at <https://www.nexperia.com>.

Definitions

Draft — The document is a draft version only. The content is still under internal review and subject to formal approval, which may result in modifications or additions. Nexperia does not give any representations or warranties as to the accuracy or completeness of information included herein and shall have no liability for the consequences of use of such information.

Short data sheet — A short data sheet is an extract from a full data sheet with the same product type number(s) and title. A short data sheet is intended for quick reference only and should not be relied upon to contain detailed and full information. For detailed and full information see the relevant full data sheet, which is available on request via the local Nexperia sales office. In case of any inconsistency or conflict with the short data sheet, the full data sheet shall prevail.

Product specification — The information and data provided in a Product data sheet shall define the specification of the product as agreed between Nexperia and its customer, unless Nexperia and customer have explicitly agreed otherwise in writing. In no event however, shall an agreement be valid in which the Nexperia product is deemed to offer functions and qualities beyond those described in the Product data sheet.

Disclaimers

Limited warranty and liability — Information in this document is believed to be accurate and reliable. However, Nexperia does not give any representations or warranties, expressed or implied, as to the accuracy or completeness of such information and shall have no liability for the consequences of use of such information. Nexperia takes no responsibility for the content in this document if provided by an information source outside of Nexperia.

In no event shall Nexperia be liable for any indirect, incidental, punitive, special or consequential damages (including - without limitation - lost profits, lost savings, business interruption, costs related to the removal or replacement of any products or rework charges) whether or not such damages are based on tort (including negligence), warranty, breach of contract or any other legal theory.

Notwithstanding any damages that customer might incur for any reason whatsoever, Nexperia's aggregate and cumulative liability towards customer for the products described herein shall be limited in accordance with the Terms and conditions of commercial sale of Nexperia.

Right to make changes — Nexperia reserves the right to make changes to information published in this document, including without limitation specifications and product descriptions, at any time and without notice. This document supersedes and replaces all information supplied prior to the publication hereof.

Suitability for use — Nexperia products are not designed, authorized or warranted to be suitable for use in life support, life-critical or safety-critical systems or equipment, nor in applications where failure or malfunction of an Nexperia product can reasonably be expected to result in personal

injury, death or severe property or environmental damage. Nexperia and its suppliers accept no liability for inclusion and/or use of Nexperia products in such equipment or applications and therefore such inclusion and/or use is at the customer's own risk.

Quick reference data — The Quick reference data is an extract of the product data given in the Limiting values and Characteristics sections of this document, and as such is not complete, exhaustive or legally binding.

Applications — Applications that are described herein for any of these products are for illustrative purposes only. Nexperia makes no representation or warranty that such applications will be suitable for the specified use without further testing or modification.

Customers are responsible for the design and operation of their applications and products using Nexperia products, and Nexperia accepts no liability for any assistance with applications or customer product design. It is customer's sole responsibility to determine whether the Nexperia product is suitable and fit for the customer's applications and products planned, as well as for the planned application and use of customer's third party customer(s). Customers should provide appropriate design and operating safeguards to minimize the risks associated with their applications and products.

Nexperia does not accept any liability related to any default, damage, costs or problem which is based on any weakness or default in the customer's applications or products, or the application or use by customer's third party customer(s). Customer is responsible for doing all necessary testing for the customer's applications and products using Nexperia products in order to avoid a default of the applications and the products or of the application or use by customer's third party customer(s). Nexperia does not accept any liability in this respect.

Limiting values — Stress above one or more limiting values (as defined in the Absolute Maximum Ratings System of IEC 60134) will cause permanent damage to the device. Limiting values are stress ratings only and (proper) operation of the device at these or any other conditions above those given in the Recommended operating conditions section (if present) or the Characteristics sections of this document is not warranted. Constant or repeated exposure to limiting values will permanently and irreversibly affect the quality and reliability of the device.

Terms and conditions of commercial sale — Nexperia products are sold subject to the general terms and conditions of commercial sale, as published at <http://www.nexperia.com/profile/terms>, unless otherwise agreed in a valid written individual agreement. In case an individual agreement is concluded only the terms and conditions of the respective agreement shall apply. Nexperia hereby expressly objects to applying the customer's general terms and conditions with regard to the purchase of Nexperia products by customer.

No offer to sell or license — Nothing in this document may be interpreted or construed as an offer to sell products that is open for acceptance or the grant, conveyance or implication of any license under any copyrights, patents or other industrial or intellectual property rights.

Export control — This document as well as the item(s) described herein may be subject to export control regulations. Export might require a prior authorization from competent authorities.

Non-automotive qualified products — Unless this data sheet expressly states that this specific Nexperia product is automotive qualified, the product is not suitable for automotive use. It is neither qualified nor tested in accordance with automotive testing or application requirements. Nexperia accepts no liability for inclusion and/or use of non-automotive qualified products in automotive equipment or applications.

In the event that customer uses the product for design-in and use in automotive applications to automotive specifications and standards, customer (a) shall use the product without Nexperia's warranty of the product for such automotive applications, use and specifications, and (b) whenever customer uses the product for automotive applications beyond Nexperia's specifications such use shall be solely at customer's own risk, and (c) customer fully indemnifies Nexperia for any liability, damages or failed product claims resulting from customer design and use of the product for automotive applications beyond Nexperia's standard warranty and Nexperia's product specifications.

Translations — A non-English (translated) version of a document is for reference only. The English version shall prevail in case of any discrepancy between the translated and English versions.

Trademarks

Notice: All referenced brands, product names, service names and trademarks are the property of their respective owners.

Contents

1. General description	1
2. Features and benefits	1
3. Ordering information	1
4. Functional diagram	2
5. Pinning information	2
5.1. Pinning.....	2
5.2. Pin description.....	3
6. Functional description	3
7. Limiting values	3
8. Recommended operating conditions	4
9. Static characteristics	4
10. Dynamic characteristics	5
10.1. Waveforms and test circuit.....	5
11. Package outline	7
12. Abbreviations	10
13. Revision history	10
14. Legal information	11

© Nexperia B.V. 2021. All rights reserved

For more information, please visit: <http://www.nexperia.com>
For sales office addresses, please send an email to: salesaddresses@nexperia.com
Date of release: 25 February 2021
